



General Certificate of Secondary Education
2023

Centre Number

--	--	--	--	--

Candidate Number

--	--	--	--

Technology and Design

Unit 2

Option C:
Product Design

MV18

[GTY23]

TUESDAY 20 JUNE, MORNING

Time

1 hour 30 minutes, plus your additional time allowance.

Instructions to Candidates

Write your Centre Number and Candidate Number in the spaces provided at the top of this page.

You must answer the questions in the spaces provided.

Do not write on blank pages.

Questions which require drawing or sketching should be completed using an H.B. pencil.

All written questions must be completed using black ink only.

Answer **all** questions.

Information for Candidates

The total mark for this paper is 100.

Quality of written communication will be assessed in Question 8.

Figures in brackets printed at the end of each question indicate the marks awarded to each question or part question.

Answer **all** questions

- 1 Wood can be joined together using different types of wood joints. Five different wood joints, labelled **A**, **B**, **C**, **D** and **E** are shown in **Fig. 1**.

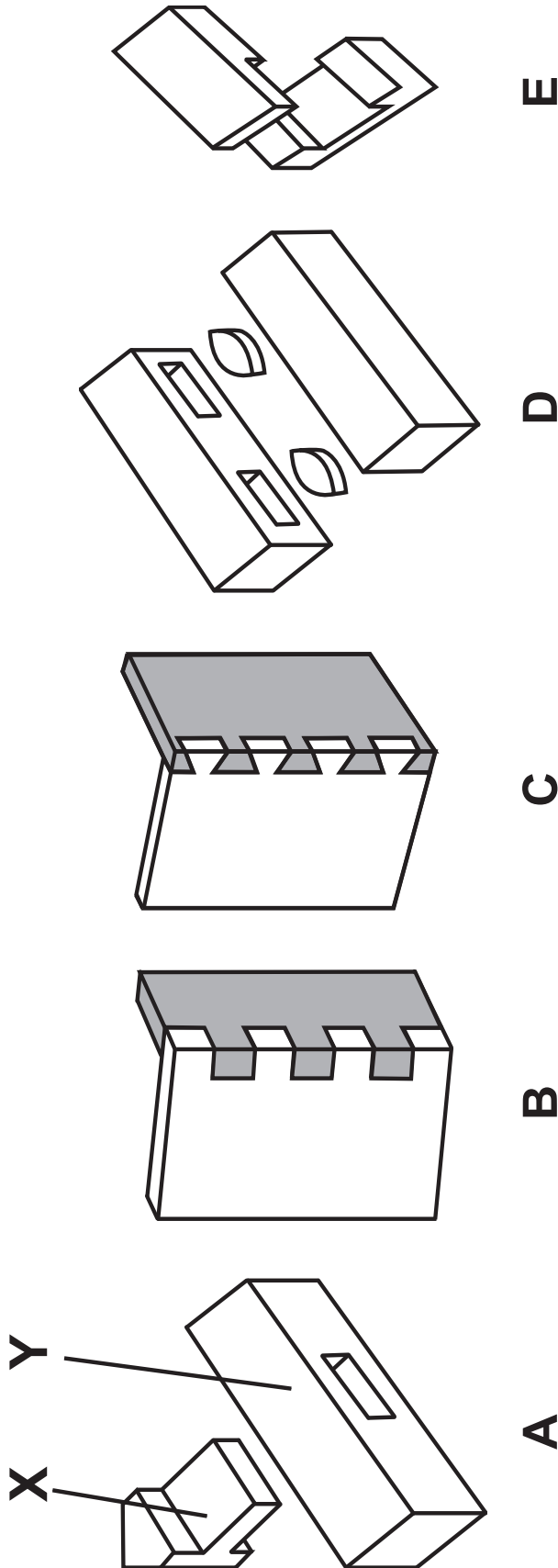

Fig. 1

(a) Name each of the wood joints shown in **Fig. 1**.

[5 marks]

A _____

B _____

C _____

D _____

E _____

(b) For the joint labelled **A**, name the parts marked **X**

and **Y**. [2 marks]

X _____

Y _____

(c) (i) Compare and outline the difference between the types of joints shown at **B** and **C**. [2 marks]

(ii) State the advantage that joint **C** offers compared to joint **B**. [1 mark]

- 2 (a) Outline what is meant by each of the following types of production processes and provide **one** reason to explain why each type of production is used in industry.

[2 marks for each]

One-off/jobbing _____

Reason _____

Batch _____

Reason _____

Mass _____

Reason _____

- (b) In a particular production process, a jigsaw and a planer are required to manufacture a product.

Outline the main purpose of a jigsaw and a planer.

[2 marks]

Jigsaw _____

Planer _____

- 3 When designing, an understanding of key aspects of the design process is essential in order to achieve good outcomes.

Discuss the importance of engaging in the following activities when designing. Each answer should focus on **three** different points which support the value of that activity. [3 marks for each]

(a) Exploring possibilities from a given design theme.

(b) The use of freehand graphical techniques and the addition of annotation to develop initial design concepts.

(c) The use of physical models or mock-ups.

- 4 **Fig. 2** shows Emeco's On and On Chair and Stools produced and designed by Edward Barber and Jay Osgerby.

Fig. 2



- (i) Describe **four** features that may be associated with Emeco's On and On Chair and Stools.

[1 mark for each]

1. _____

2. _____

3. _____

4. _____

(ii) Function and form are **two** features in product design. Does function follow form or does form follow function in the product in **Fig. 2**? [1 mark]

(iii) The collection of chairs and stools is made using recycled plastic bottles and fibreglass. The composition of each chair and stool is mainly recycled plastic bottles and 20 per cent fibreglass. Explain **three** benefits of using these materials for manufacture.

[1 mark for each]

1. _____

2. _____

3. _____

(iv) Give a reason why the On and On Chair and Stools would be mass produced. [1 mark]

(v) Technology Push is a phrase associated with this product. Explain what the term Technology Push means. [1 mark]

- 5 **Fig. 3** shows a hardwood door designed for kitchen cupboards.

Fig. 3



- (a) (i) Name a suitable hardwood for the cupboard door.
[1 mark]

- (ii) Describe **one** property of the hardwood named in part (a) (i) which makes it suitable for use as a cupboard door. [1 mark]

(b) (i) The hardwood panels for the doors are made up by gluing and clamping together two planks of hardwood each measuring $205\text{ mm} \times 2500\text{ mm} \times 20\text{ mm}$. The doors are then cut to size. Using the information given below calculate how many cupboard doors the manufacturer will obtain from 8 planks of hardwood. [3 marks]

- A hardwood door measurement is:
 $400\text{ mm} \times 600\text{ mm} \times 20\text{ mm}$

Candidates need to show their working out in the space below.

Answer _____

(ii) Calculate the percentage (%) of waste wood left from the operations in **(b) (i)**. [4 marks]

Candidates need to show their working out in the space below.

Answer _____

(c) A kitchen has a number of doors similar to that shown in **Fig. 3**. One of the kitchen doors is fitted below the kitchen sink unit. This door is to have a small waste bin attached to the inside of it.

Using clear annotated sketches and construction detail show, in the space below, how the waste bin could be attached securely to the door. The following two points need also to be considered. [10 marks]

- The waste bin should allow easy removal from the door and easy refitting. This is to enable cleaning and emptying of the waste bin when required.
- Reference should be made to all materials and components used.

Note: You are free to select the shape and material of the waste bin and other materials you may wish to use in your solution.

6 Many different types of materials are used in product design and development.

Four such materials are shown below:

- Glass reinforced plastic (GRP)
- Polymorph
- Carbon Fibre
- Shape memory alloy (nitinol)

(a) Identify the **two** composite materials from the list above.
[1 mark for each]

1. _____

2. _____

(b) Explain what is meant by a smart material. [2 marks]

(c) For each material below, discuss **two** different reasons for its use in product design. [1 mark for each]

Glass reinforced Plastic (GRP)

1. _____

2. _____

Polymorph

1. _____

2. _____

Shape memory alloy (nitinol)

1. _____

2. _____

- 7 **Fig. 4** shows a 2 litre plastic milk container. The milk container is manufactured by the blow moulding process.

Fig. 4



- (a) Outline **two** environmental benefits of recycling the plastic milk container. [1 mark for each]

1. _____

2. _____

(b) Apart from environmental considerations, discuss **two** design considerations or features that the designer would have focused on when designing the milk container shown in **Fig. 4**. [2 marks for each]

1. _____

2. _____

(c) Describe in order, **four** of the main stages in the blow moulding process. [1 mark for each]

1. _____

2. _____

3. _____

4. _____

(d) Each 2 litre container of milk is sold in a supermarket at £1.19.

Calculate the profit made by the supermarket, on each 2 litre container of milk, if the milk is bought from a dairy farmer at £190 per 1000 litres and each plastic container costs £0.03. [4 marks]

Candidates need to show their working out in the space below.

Answer _____

Blank Page

(Questions continue overleaf)

- 8 **Fig. 5** shows a folding wooden chair suitable for outdoor use. The chair is shown in the open and the folded positions. A modification is required to the chair to enable a user to enjoy a cold drink without the need to hold on to a plastic cup/bottle all of the time. This would enable the user to read a magazine or use a phone, for example. Using an annotated sketch or sketches, design a solution to solve this problem. Your solution, which should be a permanent attachment or modification, must allow the chair to be folded as before. The overall height of the chair is 850 mm. [20 marks]

Fig. 5



Open



Folded

The design solution should show evidence of the following:

- Good quality annotated sketches giving consideration to line, shape, form and proportion.
- It should be a permanent addition to the chair which is aesthetically pleasing.
- It should identify and justify the choice and thickness of material(s).
- It should identify and justify the main manufacturing techniques used in the construction.
- It should allow the chair to be folded as before.
- It should include three key dimensions to indicate size and proportion.

Use the following two pages for your answer.

Quality of written communication will be assessed in this question.

SOURCES

- Q4 © Emeco
Q5 © Getty Images
Q7 © Chief Examiner
Q8 © Chief Examiner

This is the end of the question paper

For Examiner's use only	
Question Number	Marks
1	
2	
3	
4	
5	
6	
7	
8	

Total Marks	
--------------------	--

Examiner Number

Permission to reproduce all copyright material has been applied for.
In some cases, efforts to contact copyright holders may have been unsuccessful and CCEA will be happy to rectify any omissions of acknowledgement in future if notified.